

DO BASIC SCHEMATA FACILITATE EMBODIMENT DESIGN?

Roman Žavbi, Nuša Fain and Janez Rihtaršič

University of Ljubljana, Faculty of Mechanical Engineering, Slovenia

ABSTRACT

There is a positive correlation between the number of generated alternative product concepts and their quality. Many different approaches/methods/tools have been developed to facilitate the synthesis of alternative product concepts based on variations of physical laws, materials, geometry and geometrical position. One such tool is SoPHY (**S**ynthesis of **PHY**sical laws), which is based on chaining of physical laws and complementary basic schemata. An experiment was designed as the first one in a series of planned experiments aiming to assess various aspects of use of this method/computer tool. The assumption tested in the experiment was that basic schemata generated by the computer tool (automatic phase) offer appropriate guidance for generating alternative embodiments due to a more focused approach (manual phase). The paper focuses on the presentation of this experiment and its results.

Keywords: experiment, engineering design, basic schemata, concept embodiment, computer support

1 INTRODUCTION

According to [1], there is a positive correlation between the number of generated alternative product concepts and their quality. Many different approaches/methods/tools have been developed to facilitate the synthesis of alternative product concepts based on variations of physical laws, materials, geometry and geometrical position [2].

One such tool is SoPHY (**S**ynthesis of **PHY**sical laws; available at http://www.lecad.fs.uni-lj.si/research/theory/phlaw_chains/software). It is based on the chaining of physical laws and complementary basic schemata.

The concept of using physical laws is based on four observations [2]:

- All products (i.e. engineered, discrete and physical products) function according to physical laws;
- Many products contain a chain of physical laws;
- The respective chain of physical laws can explain any product's functioning (based on stimulus–response);
- There is a complementarity(!) between a specific physical law and a specific basic scheme (which actually enables the use of physical laws for the synthesis of product concepts).

The result of chaining is a chain; this represents an elementary product concept and describes the transformation of an input quantity to an output quantity (i.e. an abstract description of the mode of action).

A basic scheme is an abstract structure which is complementary to a physical law. Such an abstract structure has certain geometry, geometric position and relevant environment (represented by material and fundamental constants). It represents a structure capable of performing the transformation of quantities according to a physical law to which it is complementary. Each physical law has only one basic scheme. The consequences of this are at least twofold: (1) basic schemata provide chances for various embodiments [3], which in turn lead to potentially inventive solutions, and (2) the set of building blocks is small (thus enabling easy database maintenance).

The method was basically comprised of two modules, namely (i) chaining of physical laws and complementary basic schemata, and (ii) embodiment design based on the chains of basic schemata. The first activity was formalized (see description of the algorithm in e.g. [2]) and mechanized, the latter step requiring a human designer. A designer's creativity is a complementary need and cannot be avoided, in order to fully exploit the potentials of methods for supporting conceptual design (as described in e.g. [4-8]). This subdivision of design activities (i.e. automatic and manual (creative)

activities) is in line with Blessing, who stated that the role of a designer is not only to provide input, but also the important reasoning component of the design process [9].

The authors got the first idea for this experiment during the concretization of a chain of physical laws and complementary basic schemata (i.e. concept) using pressure as output quantity as three different design engineers produced three different embodiments for the chain [3].

Our team therefore designed an experiment, the first one in a series of experiments planned to assess various aspects of the use of this method/computer tool. The presentation of the said experiment and its results is also the focus of this paper.

2 METHODOLOGY

Embodiment design is performed by a human designer, who uses synthesized chain(s) of basic schemata (i.e. results of automatic chaining with SoPHY (Figure 1)) as starting points. Chains of basic schemata are abstract, but here we took into consideration Hubka&Eder, who stated that a higher abstraction offers greater possibilities for variation (although at the expense of more effort by the designer) [10]. It was assumed that, although abstract, basic schemata offer guidance for alternative embodiments of synthesized chains, and they also lessen the effort required from the designer due to a more focused approach (i.e. embodiment of automatically synthesized chains).

This assumption was articulated as the following research hypothesis: The use of basic schemata offers greater possibilities for variation (i.e. alternative embodiments).

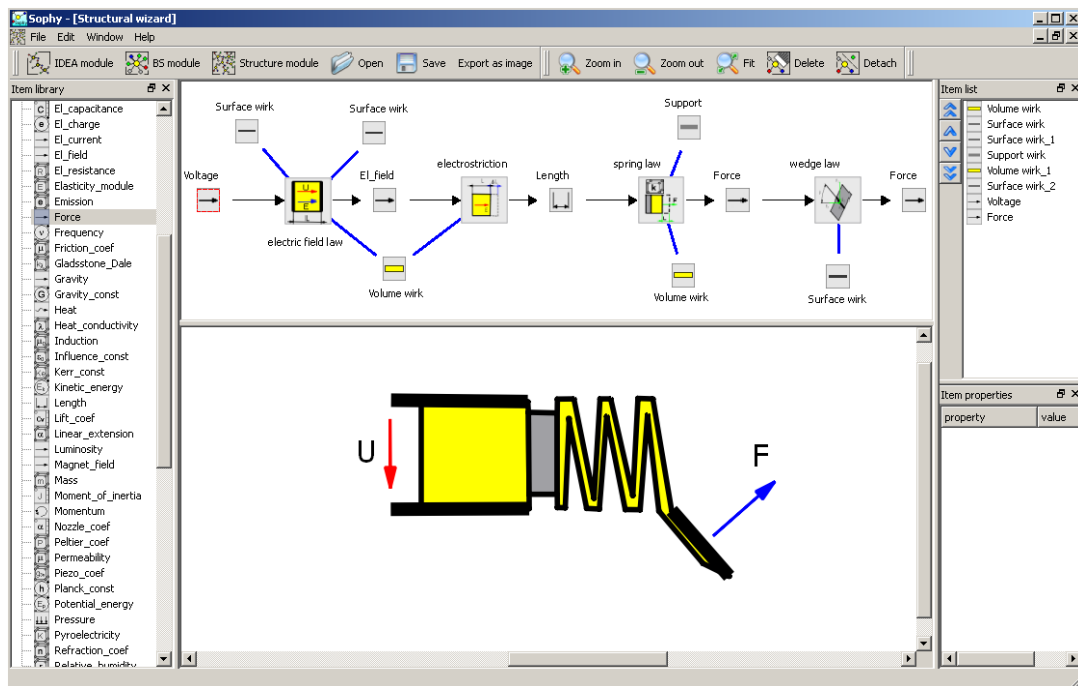

Figure 1. Structural synthesis module (A – automatically synthesized chain of basic schemata (example), B – alternative embodiment (example)) [3]

2.1 Subjects

Students attending the Design Methodology course held by the University of Ljubljana, Faculty of Mechanical Engineering, were asked to participate in an experiment. The stated course is organized in the sixth semester (out of a ten semester curriculum) of university studies, within the scope of the Design Engineering and Engineering Mechanics module, as well as the Mechatronics module.

Fifty-nine (59) of all enrolled students accepted the invitation. They all took the same courses during the first two years, predominantly related to basic and engineering sciences (e.g. Mathematics, Physics, Chemistry, Statics, Material Strength, Dynamics, Fluid Dynamics, Thermodynamics, Materials Science). The only course prior to that in which they had been exposed to some specific design tasks was Machine Elements.

2.2 Design task

The authors prepared two design tasks for the experiment. The first one involved the conceptualization of a technical system for generating electrical energy, and the second one the conceptualization of a technical system for emptying a tube (e.g. of toothpaste, of shoe cream, of paint).

Since the students were asked to use two different methods (as described in subsection 2.3), the precise Design Task 1 was as follows:

- Develop concepts for a technical system to be used for generating electrical energy. The output physical quantity can be voltage, electrical current or electrical charge, while the input physical quantity is arbitrary. The concepts should be presented by a sketch and text. Use function structure and morphological matrix.

Design Task 1 for the students who used a chain of physical laws and complementary basic schemata (generated by SoPHY) as a starting point was as follows (equations describing the physical laws in the chains were also supplied in the text, while in this paper they are omitted for brevity):

- Based on the chain of physical laws and basic schemata (Figures 2-5), an embodiment of a technical system for generating electrical energy has to be developed.

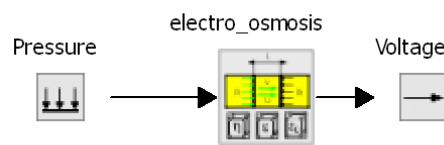

Figure 2. A chain of physical laws (1 physical law) and complementary basic schemata (1 basic schema)

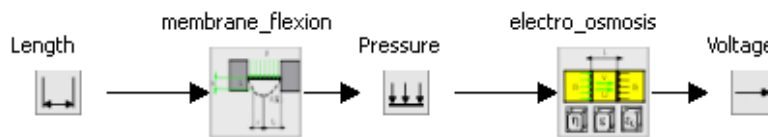

Figure 3. A chain of physical laws (2 physical laws) and complementary basic schemata (2 basic schemata)

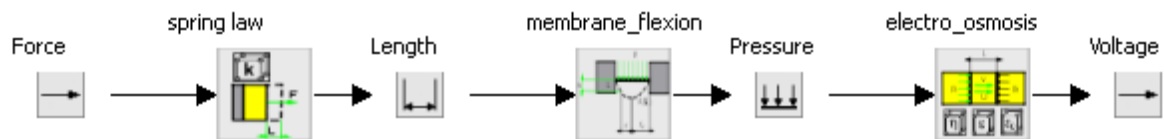

Figure 4. A chain of physical laws (3 physical laws) and complementary basic schemata (3 basic schemata)

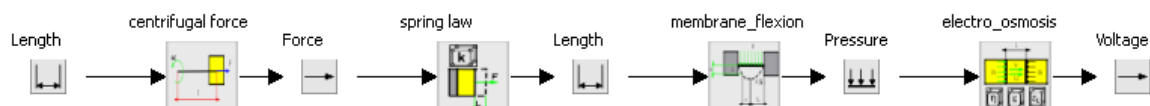

Figure 5. A chain of physical laws (4 physical laws) and complementary basic schemata (4 basic schemata)

The precise text of Design Task 2 (involving the use of function structure and morphological matrix) was as follows:

- Develop concepts for a technical system to be used for emptying a tube (e.g. of toothpaste, of shoe cream, of paint). The output physical quantity can be force or pressure, while the input physical quantity is arbitrary. The concepts should be presented by a sketch and text. Use function structure and morphological matrix.

The precise text for Design Task 2 (involving the use of a chain of physical laws and complementary basic schemata) was as follows (equations describing the physical laws in the chains were also supplied within the text, while in this paper they are omitted for brevity):

- Based on the chain of physical laws and basic schemata (Figures 6-8), an embodiment of a technical system for emptying a tube (e.g. of toothpaste, of shoe cream, of paint) has to be developed.

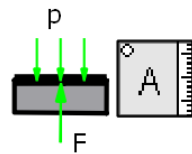

Figure 6. A chain of physical laws (1 physical law) and complementary basic schemata (1 basic schema)

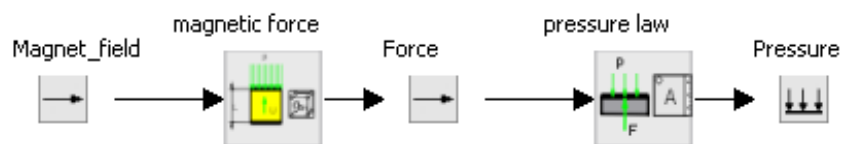

Figure 7. A chain of physical laws (2 physical laws) and complementary basic schemata (2 basic schemata)

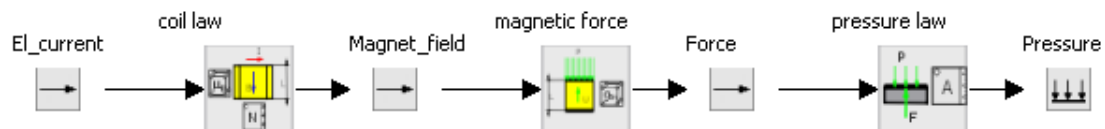

Figure 8. A chain of physical laws (3 physical laws) and complementary basic schemata (3 basic schemata)

2.3 Procedure

The experiment was performed at the end of the semester. The students were divided into two groups: the first one which used the "classical" approach (i.e. use of function structure and morphological matrix), and the second one which used chains of physical laws and complementary basic schemata (generated by the SoPHY computer tool). A short introductory course on chaining of physical laws and complementary basic schemata as well as the use of the SoPHY computer tool was organized for the first group of 23 students (called the SoPHY group), because such an approach is not part of the standard curriculum. The remaining students (36) were included in the second group (called the "Classics" group). Due to logistic problems, the "SoPHY" group was smaller than the "Classics" group, although balanced group size was planned in the preparation phase.

The time allocated was 30 minutes per design task, and the two groups solved their tasks simultaneously. The "SoPHY" group had an additional constraint: the time allocated was structured as follows: 7.5 minutes per chain (i.e. for chains with 1, 2, 3 and 4 physical laws and complementary basic schemata within the chain, respectively) for Design Task 1, and 10 minutes per chain (i.e. for

chains with 1, 2 and 3 physical laws and complementary basic schemata within the chain, respectively) for Design Task 2.

The authors used the computer tool to generate the chains, taking voltage, electrical current and electrical charge as the output quantities and subsequently they choose 4 chains for Design Task 1 ("SoPHY" group, Figure 9). In an analogous way, they performed the procedure (i.e. chose 3 chains with force/pressure as the output quantities) for Design Task 2 ("SoPHY" group, Figure 10).

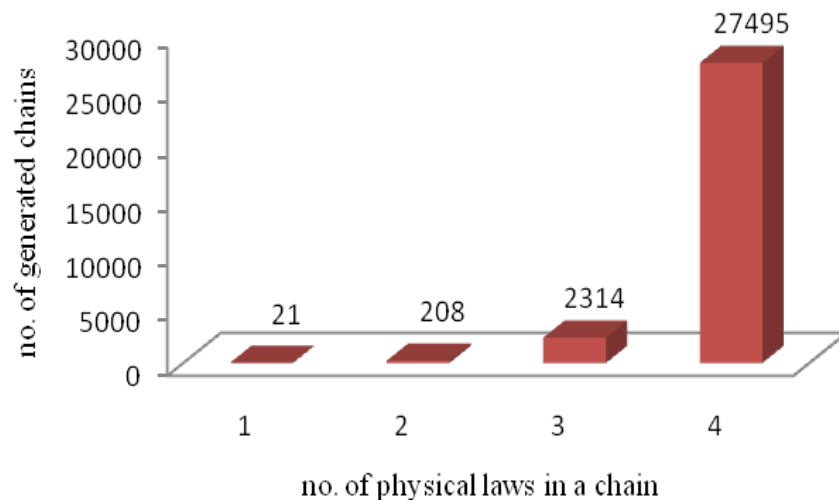

Figure 9. Histogram of generated chains for Design Task 1 ("SoPHY" group)

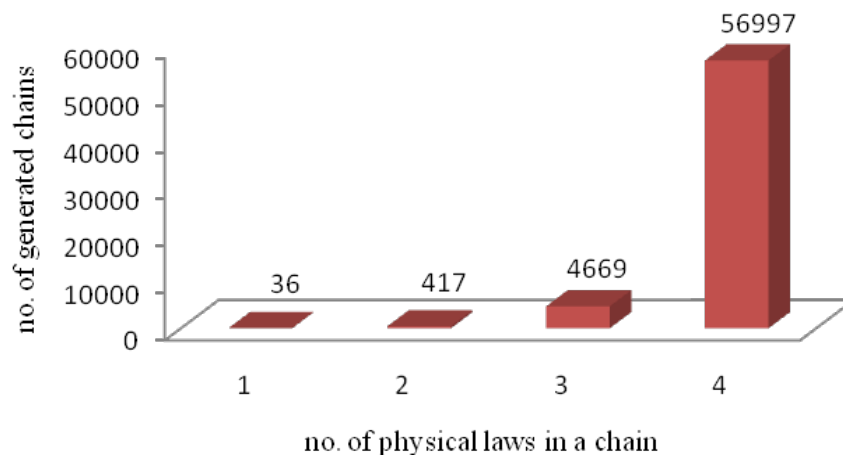

Figure 10. Histogram of generated chains for Design Task 2 ("SoPHY" group)

The solutions of the design tasks for both groups were collected and classified. The first author classified the solutions according to the task and the approach used for conceptualizing technical systems, as well as according to their content. In the "Classics" group, 36 students generated 156 solutions (44 of which were different) for Task 1 and 108 solutions (12 of which were different) for Task 2. The 23 students from the "SoPHY" group generated 85 solutions (66 of which were different) for Task 1 and 58 solutions (35 of which were different) for Task 2. Examples of these solutions are presented in Figures 11-14 below.

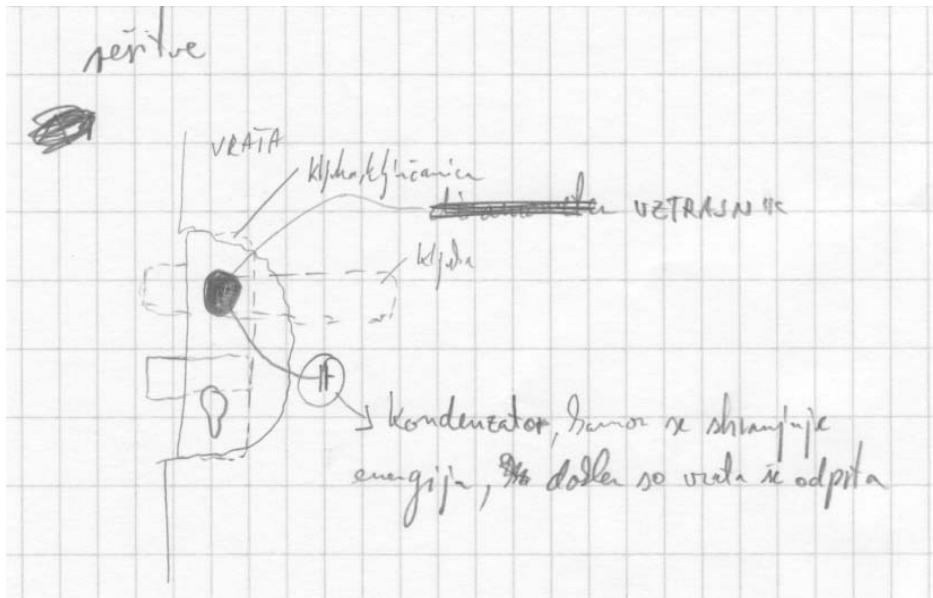

Figure 11. A solution for Task 1 by a student from the "Classics" group (actuating a door handle rotates a flywheel/dynamo, which in turn charges a capacitor)

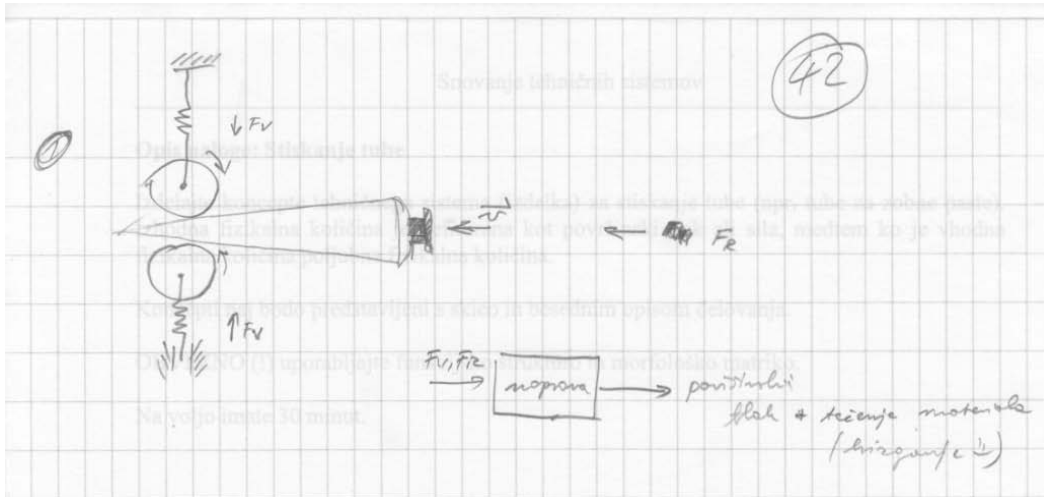

Figure 12. A solution for Task 2 by a student from the "Classics" group (pushing a tube through two spring rollers squeezes out the tube contents)

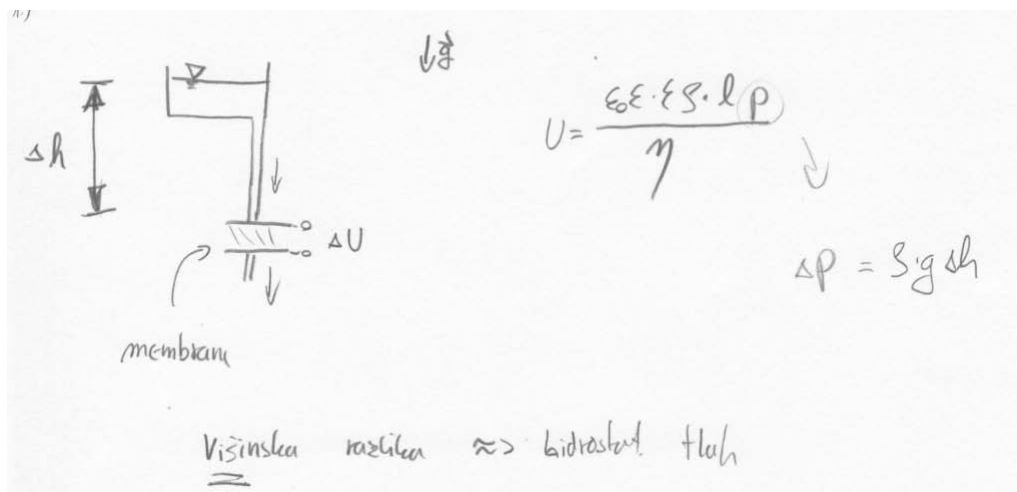

Figure 13. A solution for Task 1 (based on the chain shown in Figure 2) by a student from the "SoPHY" group (height difference pushes a fluid through a porous diaphragm and thus generates voltage)

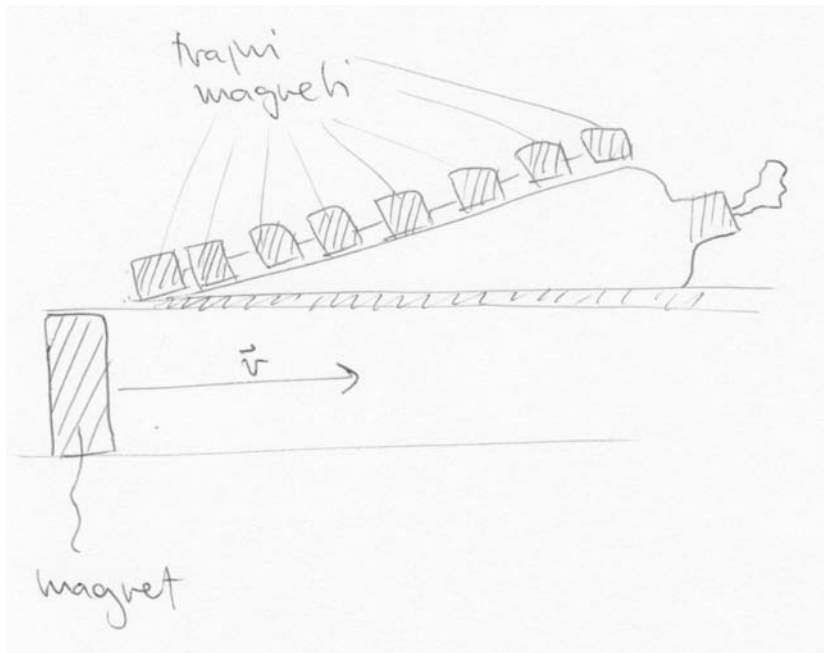

Figure 14. A solution for Task 2 (based on the chain shown in Figure 7) by a student from the "SoPHY" group (movement of a main magnet attracts smaller magnets and squeezes out tube contents)

3 DATA ANALYSIS AND RESULTS

The numbers of obtained solutions show even at first glance that the students who used chains of physical laws and complementary basic schemata managed to produce a greater number of different solutions. In order to avoid this result being accidental, statistical tools were implemented for data analysis. The calculation of chi-square (χ^2) was done in order to validate the statistical relevance of the results.

χ^2 is a tool used when the goal is to compare two independent samples and determine the relevance of their differences [11]. The basic calculation of χ^2 is done using the following formula (1):

$$\chi^2 = \sum \frac{(f_0 - f_t)^2}{f_t} \quad (1),$$

where f_0 are the obtained frequencies and f_t the theoretical (expected) frequencies one would expect for this specific hypothesis.

The results of χ^2 test are presented separately for both design tasks which the students tackled. In order to be able to calculate the relevance of the number of solutions produced by the two student groups, it is assumed that each student is capable of producing at least 1 solution to a given design task.

Table 1 presents the results of χ^2 test for Design Task 1.

The first step in obtaining valid results is to find the expected frequencies (Table 1b) which correspond to the obtained frequencies (Table 1a). These are calculated simply by multiplying the sum of the columns with the sum of the rows and then dividing that by the total sum of frequencies [11].

Table 1. Calculations of χ^2 for Design Task 1

a) Obtained frequencies

	No. of solutions		N
Classics	44	36	80
Sophy	66	23	89
	110	59	169

b) Expected frequencies

	No. of solutions		N
Classics	52.1	27.9	80.0
Sophy	57.9	31.1	89.0
	110.0	59.0	169.0

c) Calculated χ^2

f_0	f_t	$f_0 - f_t$	$(f_0 - f_t) * (f_0 - f_t)$	$(f_0 - f_t) * (f_0 - f_t) / f_0$
44	52.1	-8.1	65.1	1.5
36	27.9	8.1	65.1	1.8
66	57.9	8.1	65.1	1.0
23	31.1	-8.1	65.1	2.8
			$\chi^2 =$	7.1

Then, χ^2 is calculated (Table 1c) using the specified formula. When the value of χ^2 is obtained, it needs to be related to the appropriate sampling distribution of χ^2 [12]. This is done by using tables where χ^2 is calculated with regard to degrees of freedom and level of significance. For the purposes of this paper, the relevance of the obtained results was presumed at 5%. As for the degrees of freedom, a general formula for their calculation is (2):

$$D_f = (r - 1)(c - 1) \quad (2)$$

where r is the number of rows and c is number of columns. For the cases studied, the degree of freedom is therefore 1. When looking at the table [11], the calculated χ^2 at 1 degree of freedom and significance 5% is 3.841. As the calculated value of χ^2 for the results of Design Task 1 is higher than this, it can be confirmed that the differences in the frequencies obtained for the two studied groups are statistically relevant.

The same calculation was done for Design Task 2, and the obtained χ^2 (Table 2) again confirmed that the differences between the two studied groups were statistically significant. As both studied design tasks produced the same significant results, i.e. the students using the chains of physical laws and complementary basic schemata produced a greater number of different solutions (i.e. alternative embodiments) for the design tasks, our basic hypothesis can be confirmed, namely that using basic schemata offers greater possibilities for variation (i.e. alternative embodiments).

Table 2. Calculations of χ^2 for Design Task 2

a) Obtained frequencies

	No. of solutions		N
Classics	12	36	48
Sophy	35	23	58
	47	59	106

b) Expected frequencies

	No. of solutions		N
Classics	21.3	26.7	48.0
Sophy	25.7	32.3	58.0
	47.0	59.0	106.0

c) Calculated χ^2

f_0	f_t	$f_0 - f_t$	$(f_0 - f_t) * (f_0 - f_t)$	$(f_0 - f_t) * (f_0 - f_t) / f_0$
12	21.3	-9.3	86.2	7.2
36	26.7	9.3	86.2	2.4
35	25.7	9.3	86.2	2.5
23	32.3	-9.3	86.2	3.7
$\chi^2 =$				15.8

4 DISCUSSION

In both cases, the students from the "SoPHY" group managed to generate a greater variety of alternative solutions (i.e. embodiments). It seems that, although abstract, the chains of physical laws and complementary basic schemata have indeed lessened the effort required from the students, who could thus focus only on the embodiments of basic schemata. This great variety of alternative solutions based on the abstract chains (i.e. the results of the "SoPHY" group) is also in line with Hubka's statement that a higher level of abstraction offers greater possibilities for variation [10]; on the other hand, one may fear that basic schemata are too abstract to be supportive, or that they could even constrain students in developing their own embodiments. This great variety is also in line with Rusák's statement that the variety of structural solutions (i.e. concept embodiments) is at least as large as the variety of (abstract) concepts [13]. The design tasks given were simple and involved no requirements (except for the main function) for the generated concepts, thus allowing the students to focus more on the evaluation of variety and less on the quality of fulfilment of additional requirements. More complicated tasks would also require more time to generate solutions.

The authors were somehow surprised that the "Classics" group generated a relatively small number of different alternative solutions for Design Task 2. It seems that, being allowed to propose solutions without guidance (contrary to the SoPHY group, which used the chains of basic schemata as guidance) and within the time given for Design Task 2, they were inclined to mainly propose those already known to them (i.e. variations of some commercial solutions). It could be speculated that the students would have generated more inventive alternative solutions, had the allowed time for the completion of the design tasks been longer.

The authors of the paper selected chains of physical laws and basic schemata for Design Tasks 1 and 2 of the "SoPHY" group. A relevant question regarding the "SoPHY" group's procedure would concern the approach these students would have used had there been no prior selection of the chains. It is speculated that in that case, the students would have first tried to make embodiments of the chains with 1 physical law per chain, then 2, and so forth. This is because such an approach would be in line with the suggested approach for managing the plethora of generated chains; more physical laws per chain would mean more transformations and consequently a lower efficiency of such chains [2].

The described procedure used in the experiment might also have a bias, namely that the first author is also a co-author of the SoPHY computer tool and he may have overestimated the variety of the solutions generated by the students from the "SoPHY" group. This will be checked in the near future by several independent design engineers who will classify the design solutions generated by the students of the two groups.

5 CONCLUSION

Based on this experiment, it can be concluded that the use of basic schemata facilitates the variety of alternative embodiments by offering appropriate guidance to "SoPHY" computer tool users. Further experiments will also be designed in order to enable us to test other hypotheses (e.g. regarding the influence of the used method on the quality of concept designs) which will be part of our future work. However, it is even more important that this (simple) experiment has raised some new questions and has consequently demonstrated the complexity of experimental evaluation of computer tools in the conceptual design phase, bearing in mind the speculations presented in the Discussion section.

REFERENCES

- [1] Andreasen, M.M., Hein, L. *Integrated product development*, Institute for Product Development, (Technical University of Denmark, Lyngby), 1987, Reprint 2000
- [2] Žavbi, R., Rihtaršič, J. Synthesis of elementary product concepts based on knowledge twisting, *Research in Engineering Design*, 2010, 21, 69-85
- [3] Rihtaršič, J., Žavbi, R., Duhovnik, J. Properties of elementary structural elements for synthesis of conceptual technical systems, in Proc. International Conference on Research into Design, ICoRD'09, Bangalore, January 2009, pp. 11-17
- [4] Bracewell, R. Synthesis based on function-means trees: schemebuilder, in Chakrabarti, A. (ed.), *Engineering design synthesis*, (Springer, London), pp. 199–212, 2002
- [5] Chakrabarti, A., Langdon, P., Liu Y-C, Bligh, T.P. An approach to compositional synthesis of mechanical design concepts using computers, in Chakrabarti, A. (ed.), *Engineering design synthesis*, (Springer, London), pp. 179–197, 2002
- [6] Lossack, R.S. Design processes and context for the support of design synthesis, in Chakrabarti, A. (ed.), *Engineering design synthesis*, (Springer, London), pp. 213–227, 2002
- [7] Shai, O., Reich, Y., Rubin, D. Creative conceptual design: extending the scope by infused design, *Computer Aided Design*, 2009, 41, 117-135
- [8] Ziv-Av, Reich, Y. SOS-subjective objective system for generating optimal product concepts, *Design Studies*, 26, 509-533
- [9] Blessing, L.T.M. *A process-based approach to computer supported engineering*, Ph.D. thesis, (University of Twente), 1994
- [10] Hubka, V., Eder, E. Theory of technical systems and engineering design synthesis, in Chakrabarti, A. (ed.), *Engineering design synthesis*, (Springer, London), pp. 49–66, 2002
- [11] Petz, B. *Statistical methods for nonmatematicians*, (Naklada Slap, Zagreb), 2007 (in Croatian)
- [12] Guilford, J.P. *Fundamental statistics in psychology and education*, (McGraw-Hill Book Company, New York), 1965
- [13] Rusák, Z. Vague Discrete Interval Modeling for Product Conceptualization in Collaborative Virtual Design Environments, Ph.D. thesis, (Delft Technical University), 2003

Contact: Roman Žavbi
University of Ljubljana
Faculty of Mechanical Engineering
Laboratory for Engineering Design-LECAD
Aškerčeva 6
SI-1000 Ljubljana
Slovenia
Tel: +386 1 4771 412
Fax: +386 1 4771 156
Email: roman.zavbi@lecad.fs.uni-lj.si
URL: <http://www.lecad.fs.uni-lj.si>

Roman Žavbi is Associate Professor of Engineering Design at the Faculty of Mechanical Engineering at the University of Ljubljana. He teaches and researches in engineering design and computer-aided design. He is interested in many aspects of design and computing, in particular how computer aids can assist a (student) design engineer.