

A DESIGN METHOD THAT INTEGRATES THE EARLY AND LATE PROCESS OF DESIGN

Yuji Nomura¹, Yoshiki Ujii² and Yoshiyuki Matsuoka²

¹Graduate School of Science and Technology Keio University

² Faculty of Science and Technology Keio University

ABSTRACT

The demands of users are diverse. In design, a derivation of exact design solution is important for responding to the diverse demands of users. It is necessary for achieving the derivation of exact design solution to properly connect the early to the late process of design. In the early process of design, the demands of users are considered and the structural model is often used. On the other hand, in the late process of design, a design solution responding to the demands of users is derived and the mathematical model is often used. In the conventional studies, the design methods that contribute to each model building have been proposed. However, a design method that integrates the building of both models has not been proposed. Firstly, the Integrated Design Model was paid attention to, and the Integrated QFD, to which the ISM method was introduced, was proposed as the structural model building method that reflects the features of the Integrated Design Model. Secondly, the design factor selection method was proposed based on the Integrated QFD. Thirdly, a design method that has an ability to integrate the building of both models was proposed using the Integrated QFD and the design factor selection method. Finally, the effectiveness of the proposed design method was confirmed by applying to a driver seat designs. Thus, this study represented a design method that effectively promoted the early and late process of design and indicated the possibility of deriving exact design solution by using the Integrated Design Model.

Keywords: QFD, design method, design model

1 INTRODUCTION

The demands of users are diverse. In design, a derivation of exact design solution is important for responding to the diverse demands of users. The demands of users are considered in the early process of design, and a design solution responding to the demands of users is derived in the late process of design. Consequently, it is necessary for achieving the derivation of exact design solution to properly connect the early to the late process of design.

In the early process of design, the demands of users are considered by qualitative design as represented by industrial design. For example, in a seat design, various design elements including "comfortable" and "relax" are extracted. Then design proposals are derived based on these various design elements by designers. During the derivation of design proposals, a qualitative structural model (the structural model) that describes the structure of design elements is built and is used for derivation of design proposals [1], [2]. In brief, in the early process of design, the structural model is often used. On the other hand, in the late process of design, a design solution responding to the demands of users is derived by quantitative design as represented by engineering design. For example, a design proposal is quantified and a quantitative mathematical model (the mathematical model) is derived like an objective function and a constraint condition. Then an optimum solution is derived from the relationship between an objective function and a constraint condition [3]. In brief, in the late process of design, the mathematical model is often used.

As described above, as shown in Fig1, the design process is described by the use of model that abstracts design. Besides, there is a tendency that the structural model is often used in the early process of design and the mathematical model is often used in the late process of design. In the conventional studies, the design methods that contribute to each model building have been proposed, while a design method that integrates the building of both models has not been proposed. However, as

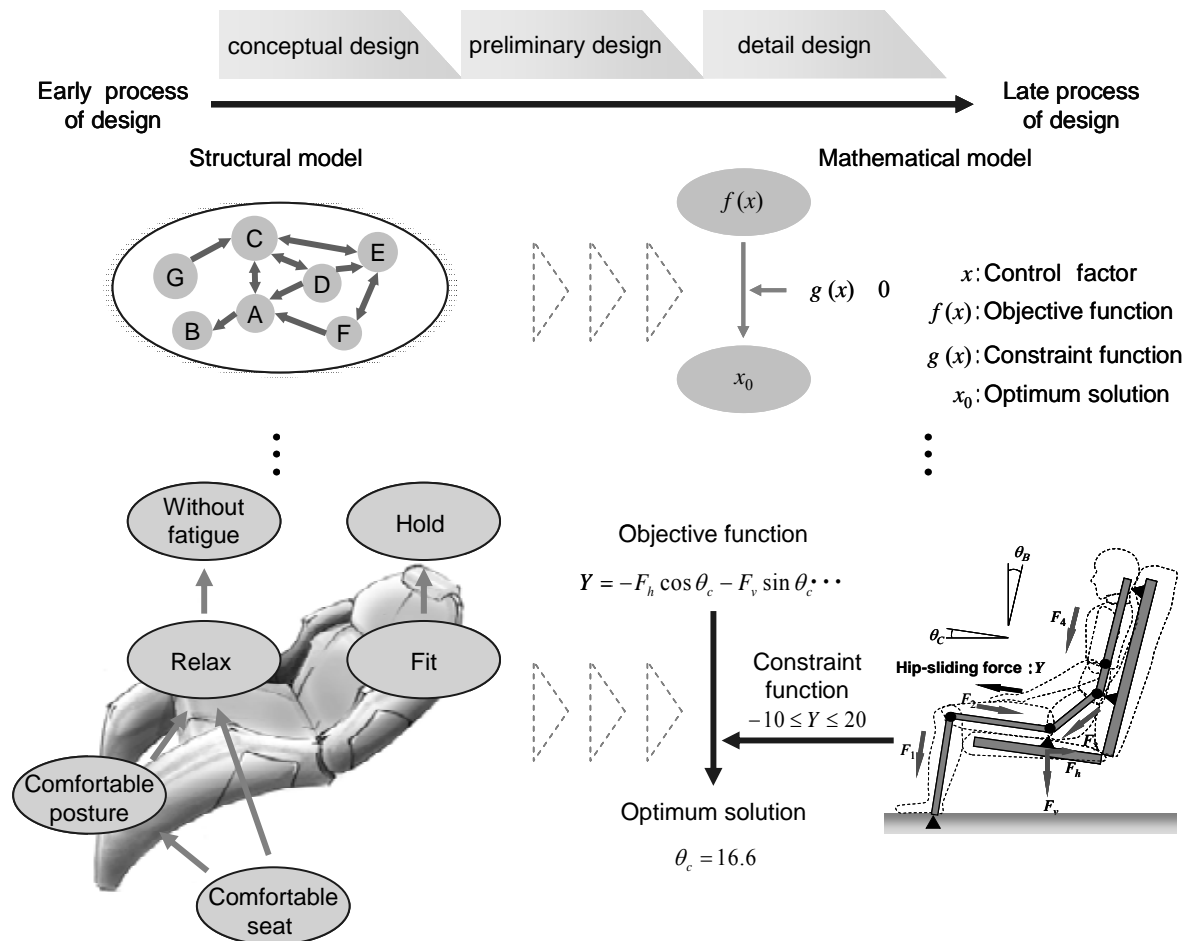

Figure 1. The early to late process of design

such a design method is regarded as the method that properly connects the early to the late process of design, it is contemplated that the proposal helps the derivation of exact design solution. Consequently, the objective of this study is the proposal of a new design method that integrates the building of both models by properly connecting the structural model building in the early process of design to the mathematical model building in the late process of design. Moreover, the effectiveness of the proposed design method is verified by applying to automotive seat designs. In this study, as a guideline that connects the early to the late process of design, the Integrated Design Model was paid attention to as shown in Figure 2 [4].

2 THE INTEGRATED DESIGN MODEL

In this study, as a viewpoint of the new design method, the Integrated Design Model was paid attention to. This chapter describes the general appearance of the Integrated Design Model. Then, the Integrated Design Model describes design process.

2.1 The general appearance of the Integrated Design Model

The Integrated Design Model is a model of the designing relating to artifacts. The Integrated Design Model consists of the knowledge space and the thinking space. Thinking space is divided into two spaces. One is the physical space that consists of the attribute space and the state space. Another is the psychological space that consists of the meaning space and the value space. Each space is defined as follows.

- The attribute space is a set of the attribute elements. The attribute elements are geometrical and physical property of artifacts. For example, dimension and material like being shown in the technical drawing and so forth.
- The state space is a set of supposed condition and the state elements. The condition is physical environment for which artifacts are used. For example, time, external force, body height of users

and so forth. The state elements are physical quantity generated when artifacts are in a condition. For example, stress, acceleration produced when an external force acts on artifacts and so forth.

- The meaning space is a set of the meaning elements. The meaning elements are psychological elements relating to meaning that user thinks about artifacts. For example, function, image, and so forth.
- The value space is a set of the value elements. The value elements are psychological elements relating to value that user thinks about artifacts. For example, functional value, cultural value, and so forth.

In addition, elements in each space are design elements. Then, in the Integrated Design Model, the designing is defined as a practice of deriving design elements in a space from design elements in another space. For example, it is a practice of deriving “a structure of cushion (the attribute element)” in the attribute space from “relax (the meaning element)” that is meaning element in the meaning space. However, it is necessary for deriving “a structure of cushion” to know relationship between “a structure of cushion” and “relax” beforehand to some degree. In brief, it is necessary for the designing to know relationship between design elements beforehand to some degree. Generally, the practice of knowing such relationships is called “analysis”. In the Integrated Design Model, “analysis” consists of a practice of searching the relationship between design elements in different spaces (the modeling between different spaces) and a practice of searching the relationship between design elements in the same space (the modeling in the same space).

2.1 The design process described by Integrated Design Model

As a feature of design process, in the early process of design, diverse design solutions are derived by dealing trial and error and interactive with design elements that differ in quality like psychological design elements and physical design elements. On the other hand, in the late process of design, a unique design solution is derived by unidirectional dealing with physical design elements. The Integrated Design Model describes the design process as shown in Figure 3. Figure 3 shows interactive design of psychological design elements and physical design elements in the early process of design, and unidirectional design of physical design elements in the late process of design. In brief, position of both designs in design process is described by the Integrated Design Model. This is due to the following feature of the Integrated Design Model: four kinds of design elements, the modeling between different levels, and the modeling in the same level.

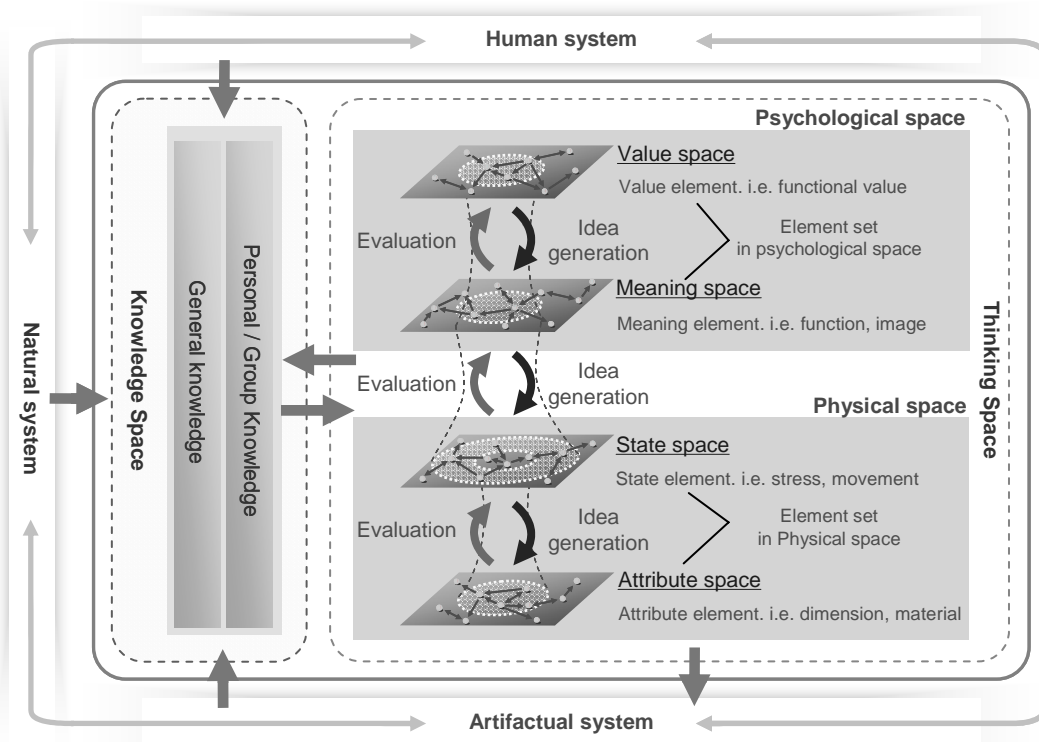

Figure 2. Integrated Design Model

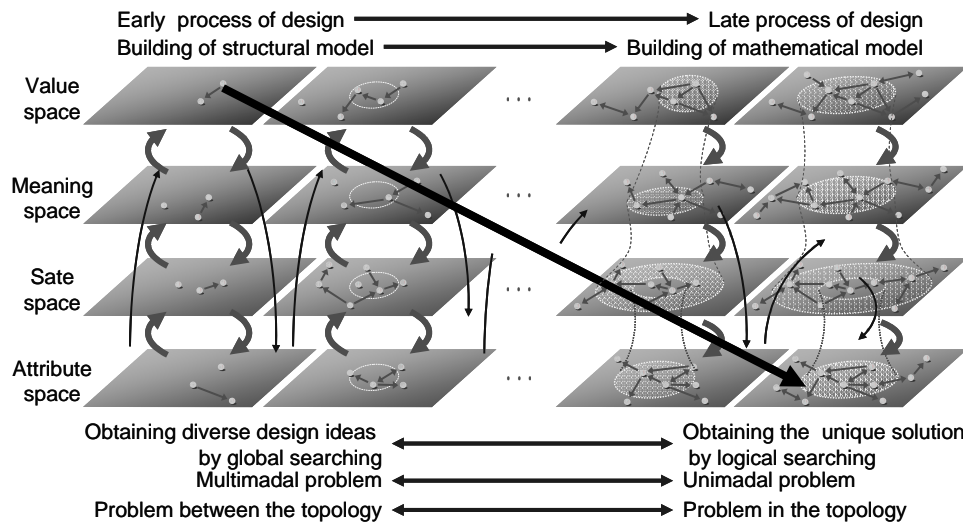

Figure 3. The early to late process of design described by Integrated Design Model

As described above, The Integrated Design Model has ability to deal comprehensively with the early and the late process of design. Consequently, it is possible to propose a design method that has an ability to integrate the building of both the structural model in the early process of design and the mathematical model in the late process of design by proposing a design method that reflects the features of the Integrated Design Model.

3 A DESIGN METHOD BASED ON THE INTEGRATED DESIGN MODEL

In the design process, it is necessary for connecting the structural model to the mathematical model properly to propose a design method that has an ability to build the mathematical model based on the structural model that is built in the early process of design. Here, both models describe the same design problem from each viewpoint. In brief, the design factors necessary for building a mathematical model are included in the design elements that compose the structural model. Consequently, it is possible to connect both models by proposing a design method, the design factors selection method, that has ability to select the design factors from the design elements in the structural model, so that proposal of a design method that has an ability to integrate the building of both models become possible. For proposing this design factors selection method, the nature of the design factors has to be described by the structural model. In brief, it is necessary that both the relationship between design elements in the structural model and the nature of the design factors are described from the same viewpoint. However, design elements complexly intertwine, and have not only direct impact but also sidebar impact on each other. Consequently, it is necessary to propose a design method, the structural model building method, that builds the structural model that has an ability to grasp clearly sidebar impacts as well. In this study, both the structural model building method and the design factors selection method were proposed, which reflects the features of the Integrated Design Model that has an ability to deal comprehensively with the relationship between design elements in the structural model and the nature of the design factors.

3.1 The structural model building method

The Integrated QFD (Quality Function Deployment) was proposed as a structural model building method that reflects the features of the Integrated Design Model. The Integrated QFD is an expanded design method by reflecting the features of the Integrated Design Model to QFD that has been widely used in quality management as shown in Figure 4 [5]. The Integrated QFD consists of three two-way tables describing each modeling between different spaces and four correlation tables describing each modeling in the same space. Besides, the Integrated QFD has an ability to build a structural model that reflects the features of the Integrated Design Model by describing the relationship between design elements in the tables. Moreover, the Integrated QFD was expanded into a design method that has an ability to grasp clearly sidebar impacts by introducing Interpretive Structural Modeling method, the ISM method, that visually expresses the complex relationship of effects between design elements [6].

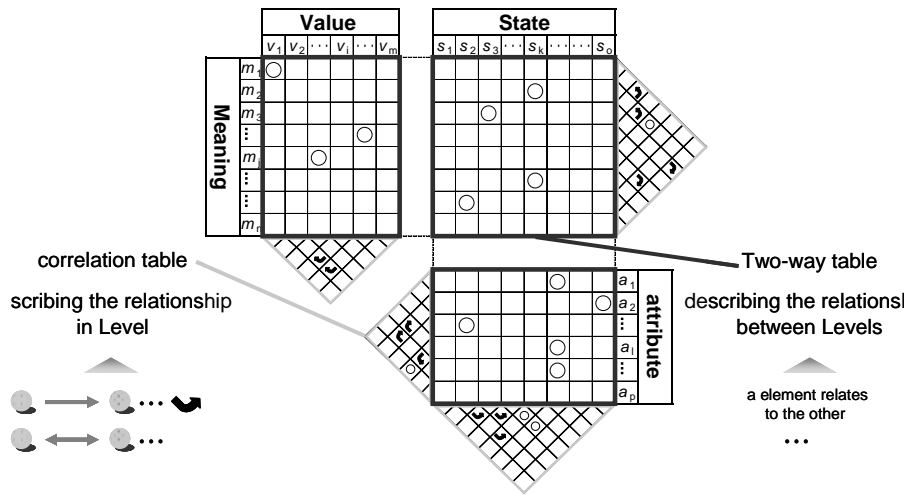

Figure 4. The Integrated QFD

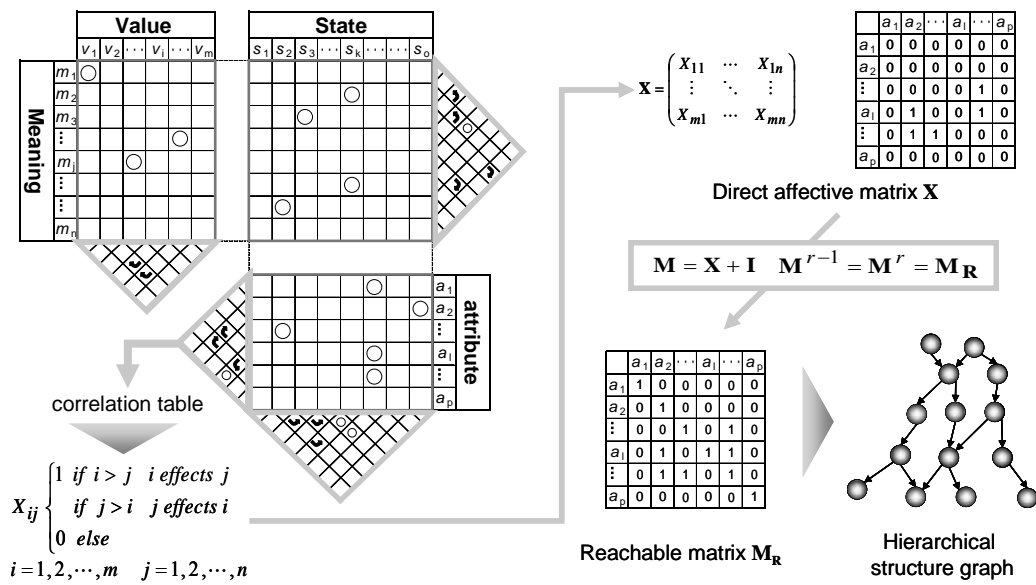

Figure 5. The ISM method

The ISM method is the design method that has an ability to visually express the complex relationship of effects between design elements by using the concept of matrix. Specifically, the Integrated QFD was expanded into as follows. Firstly, the relationship of modeling in the same space was described by the direct affective matrix \mathbf{X} , as shown the following equation.

$$X_{ij} = \begin{cases} 1 & \text{if } i > j \text{ } i \text{ effects } j \\ & \text{if } j > i \text{ } j \text{ effects } i \\ 0 & \text{else} \end{cases} \quad \mathbf{X} = \begin{pmatrix} X_{11} & \cdots & X_{1n} \\ \vdots & \ddots & \vdots \\ X_{m1} & \cdots & X_{mn} \end{pmatrix} \quad (1)$$

$i=1,2,\dots,m \quad j=1,2,\dots,n$

Secondly, the reachable matrix \mathbf{M}_R was derived by calculating the direct affective matrix \mathbf{X} as shown the following equation.

$$\mathbf{M} = \mathbf{X} + \mathbf{I} \quad (2)$$

$$\mathbf{M}^{r-1} = \mathbf{M}^r = \mathbf{M}_R \quad (3)$$

Finally, as shown in Figure 5, it is possible to build the hierarchical structure graph that visually expresses the relationship of modeling in the same space based on the reachable matrix \mathbf{M}_R . Consequently, the Integrated QFD has an ability to accurately grasp the relationships between design elements by introducing the ISM method.

3.2 The design factors selection method

In general, an objective characteristic, a control factor, a noise factor, and a constraint factor are necessary for building a mathematical model. An objective characteristic is the physical quantity that properly expresses a design object, a control factor is the physical quantity that controls an objective characteristic, a noise factor is the design element that fluctuates an objective characteristic, and a constraint factor is the design element that limits a control factor. In the Integrated Design Model, those are interpreted as follows. Firstly, because a design object is the design element in the meaning space, an objective characteristic is the design element in the state space relating to the design element that expresses a design object in the meaning space. Secondly, because a control factor is the physical quantity that controls an objective characteristic, a control factor is the design element in the attribute space. However, if a control factor has interaction with the other design elements, the use of a control factor is difficult. In brief, a control factor is the design element that does not have an interaction in the attribute space. Thirdly, because a noise factor fluctuates an objective characteristic, a noise factor is not controlled by a designer. In brief, a noise factor is the design element that relates to an objective characteristic and is not controlled by a designer in the state space. Finally, because a constraint factor limits a control factor, a constraint factor is the design element that relates to a control factor in elements with constraint of limiting value and so forth.

As described above, as shown in table1, the design factor selection method was proposed. Then, the design factors are selected by applying the design factor selection method to the Integrated QFD in the preceding section. Moreover, depending on the case, a mathematical model is built based on the selected design factors. In addition, a control factor and a noise factor are used in the robust design that ensures robust performance in considering the variation of products [7]. In usual optimization, a control factor is called a design variable, and a noise factor is not considered.

3.3 Proposal of a design method that has an ability to integrate both models

As shown in Figure 6, a design method that has an ability to integrate the building of both the structural model in the early process of design and the mathematical model in the late process of design was proposed by the proposal of the Integrated QFD and the design factor selection method. Here, general uses of QFD are the derivation of attribute value and importance against needs of design based on the relationship between elements in QFD and so forth. Consequently, the proposed design method is new in the viewpoint of supporting the mathematical model building by using the relationship between design elements in QFD.

Table 1. The design factors selection method

	Nature	Selection method
Objective characteristic	Physical quantity that properly expresses design target	In state space, design element that corresponds to design target
Design factors that relates to an objective characteristic	Control factor	In attribute space, design element that relates to objective characteristic and has no interactions with the other
	Noise factor	Design element that relates to objective characteristic and is not controlled by designer
	Constraint factor	Design element that relates to control factor in elements with constraint of limiting value and so forth

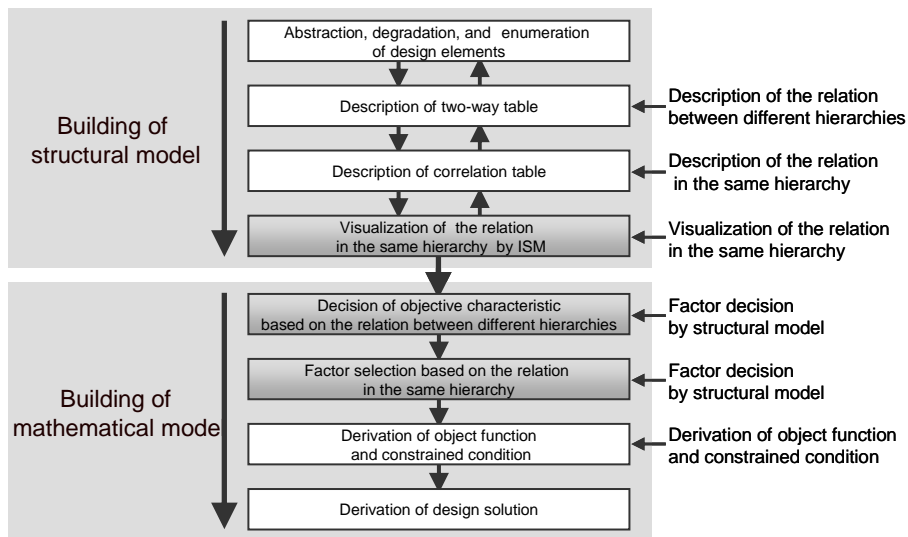

Figure 6. The proposed design method that has ability to integrate both models

4 AN APPLICATION TO AUTOMOTIVE SEAT DESIGNS

The proposed design method was applied to automotive seat designs in order to verify its effectiveness. The automotive seats are usually categorized into a driver seat and a passenger seat. The driver seat is a work seat for pedal operation and so forth, while the passenger seat is a comfort seat. The proposed design method was applied to a driver seat design for reducing hip-sliding force that affects comfort and fatigue.

4.1 The structural model building

Firstly, the design elements relating to this seat design were extracted based on literature researches about automotive seat [8], [9], [10]. Secondly, the relationship between design elements were described in two-way tables and correlation tables in the Integrated QFD by incorporating the opinions of influential individual. As a result, as shown in Figure 7, the structural model with respect to reducing hip-sliding was built by the Integrated QFD. Moreover, as shown in Figure 8, hierarchical structures of each space were built by the ISM method. Consequently, the structural model that has an ability to accurately grasp the relationships between design elements was built.

4.2 The mathematical model building

Following the preceding section, as shown in table 2, the design factors were selected from the structural model by the design factor selection method. For example, an objective characteristic and a control factor were selected as follows. Firstly, as shown in table1, an objective characteristic is the design element that corresponds to design target in the state space. Because design target of this seat design is without hip sliding, as shown in Figure 7, hip-sliding force was selected as an objective characteristic by paying attention to two-way table of meaning space and state space in the Integrated QFD. Secondly, as shown in table1, a control factor is the design element that relates to objective characteristic and has no interactions with the other in attribute space. Here, as shown in Figure 8, cushion angle was the design element that has no interactions by paying attention to hierarchical structure graph in attribute space. As shown in Figure 7, cushion angle did not have direct impact with hip-sliding force that is an objective characteristic by paying attention to two-way table of state space and attribute space in the Integrated QFD. However, as shown in Figure 8, cushion angle relates to hip-sliding force through the other design elements by paying attention to hierarchical structure graph in state space. Consequently, cushion angle was selected as a control factor. As a result, as shown in Figure 9, an objective function and a constraint function have been derived based on the selected design factors. As described above, design factors were selected properly by applying the design factor selection method to the structural model that has an ability to accurately grasp the relationships between design elements. The mathematical model was built.

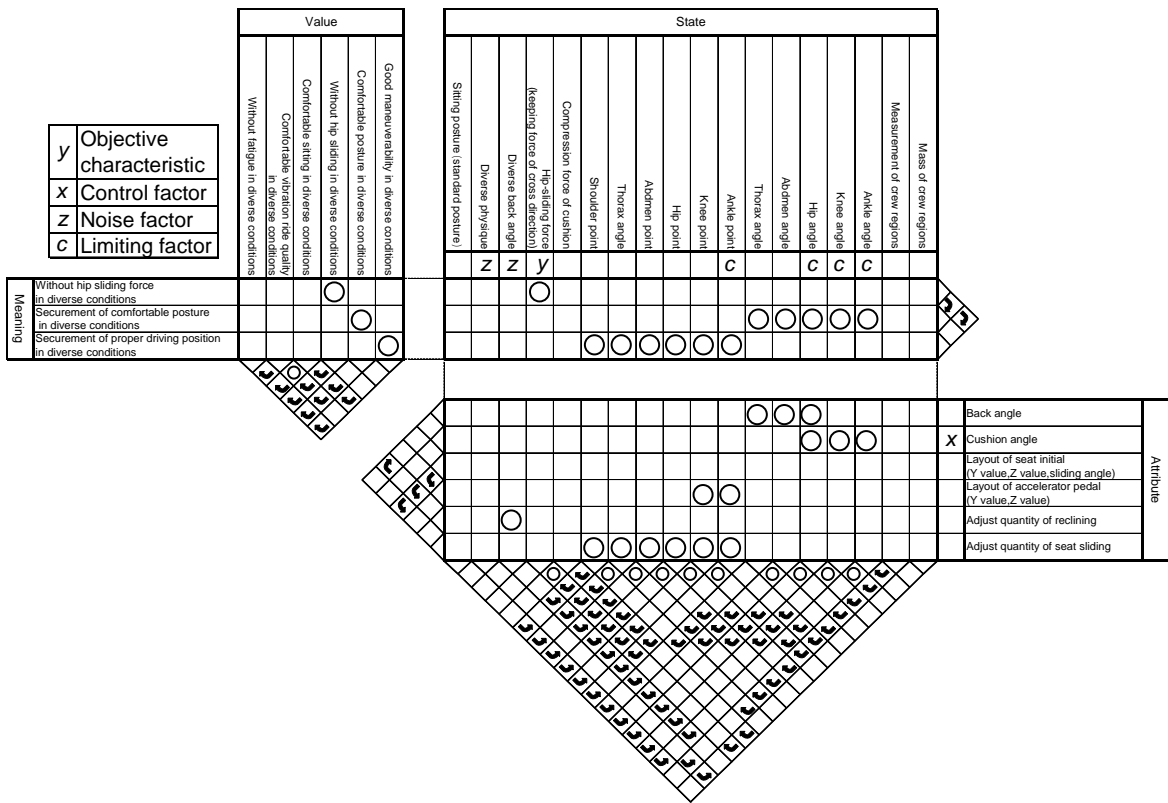

Figure 7. A structural model in a driver seat

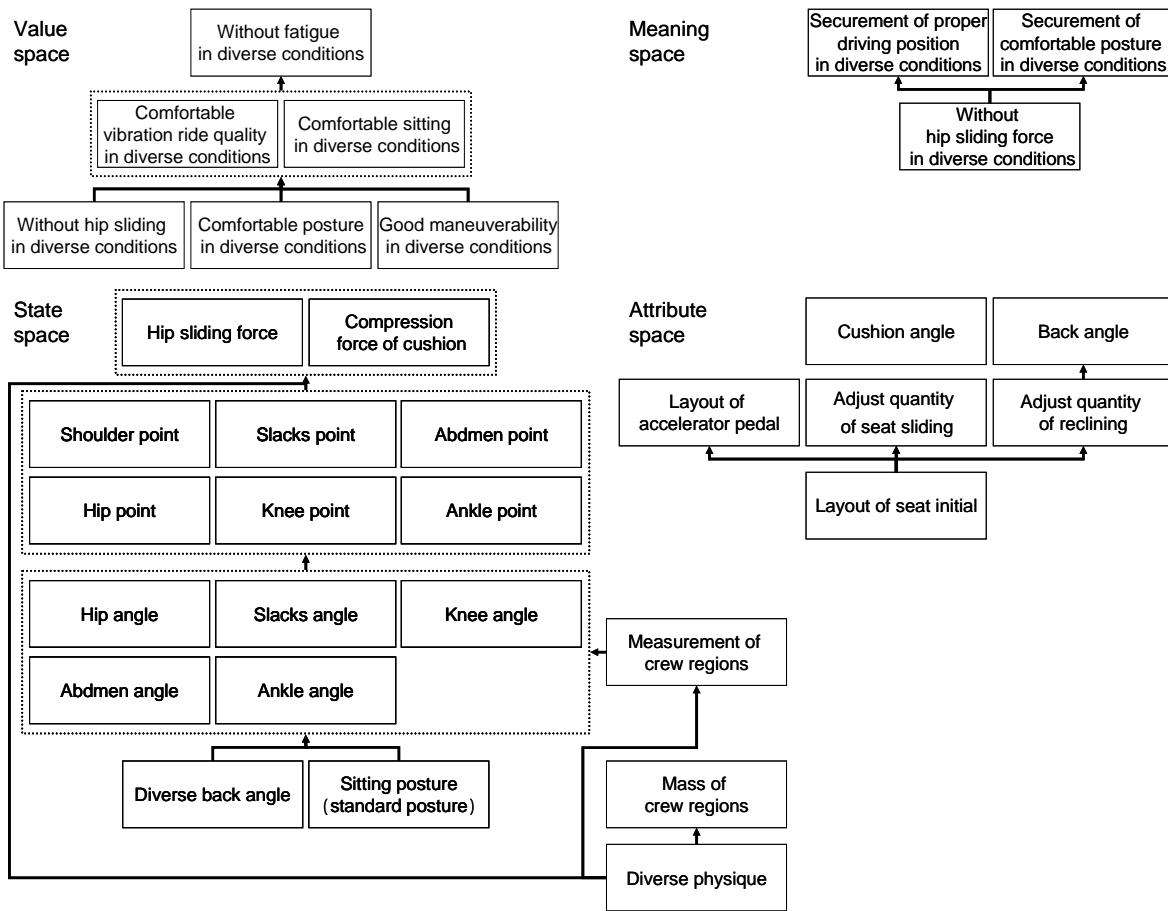
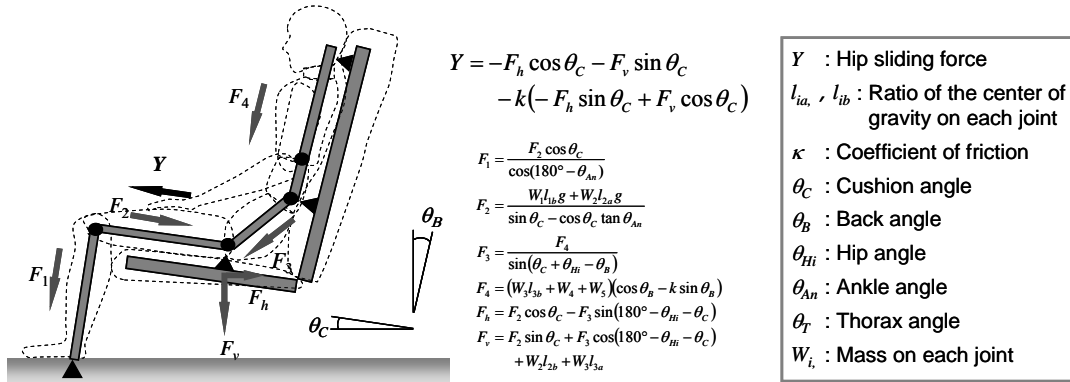

Figure 8. A hierarchical structure graph in a driver seat

Table 2. The design factors in a driver seat

		Driver seat
Objective characteristic		Hip-sliding force
Design factors that relates to an objective characteristic	Control factor	Cushion angle
	Noise factor	Diverse physique Diverse back angle
	Constraint factor	Ankle angle Ankle point



(a) Objective function

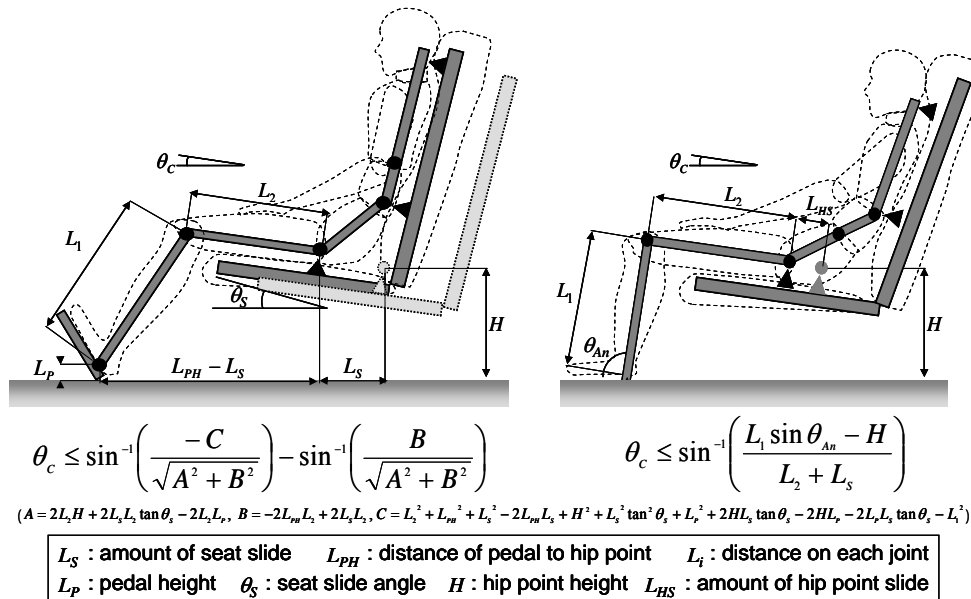

(b) Constraint function

Figure 9. A mathematical model in an automotive seat

In this seat design, because variations including sitting posture and physique of a user were considered, an optimum solution was derived by optimization of the mathematical model based on robust design method. Moreover, the effectiveness of the proposed design method was verified by a sensory evaluation using a preproduction seat with an optimum solution. As a result, it was recognized to not only prevent hip-sliding but also keep comfort and good operability. Consequently, the effectiveness of the proposed design method was confirmed.

5 CONCLUSION

In this study, the Integrated Design Model was paid attention to, firstly, The Integrated QFD was proposed as the structural model building method that reflects the features of the Integrated Design Model. Moreover, the Integrated QFD was expanded into a design method that has an ability to grasp clearly sidebar impacts by introducing the ISM methods. Secondly, the design factor selection method was proposed based on the Integrated QFD. Thirdly, a design method that has an ability to integrate the building of both the structural model in the early process of design and the mathematical model in the late process of design was proposed by the proposal of the Integrated QFD and the design factor selection method. Finally, the effectiveness of the proposed design method was confirmed by applying to a driver seat designs. Thus, this study represented a design method that effectively promoted the early and late process of design and indicated the possibility of deriving exact design solution by using the Integrated Design Model.

In addition, this work is supported in part by Grant in Aid for the 21st Century Center of Excellence for "System Design: Paradigm Shift from Intelligence to Life" from Ministry of Education, Culture, Sport, and Technology in Japan.

REFERENCES

- [1] **Amir Ziv-Av, Yoram Reich**, SOS – subjective objective system for generating optimal product concepts, *Design Studies*, 2005, 26, 5, pp509-533
- [2] **Noguchi H**, The Design Process Model for Developing Methods of Idea Generation Support. A Framework for Idea Generation Support in Industrial Design. (No.3), *Bulletin of Japanese society for the science of design*, 1996, 43, 1, pp19-24
- [3] **Yoshiyuki Matsuoka, Atsushi Morita**, Selection and Optimization of Robust Seat Functions for Assuring Comfortable Sitting Posture, *Bulletin of Japanese society for the science of design*, 2002, 48, 6, pp69-76
- [4] **Yoshiyuki Matsuoka**, (2005), The Coming Paradigms of Design and Engineering Backgrounds and Overviews Two Types of Design, *Japan Society of Mechanical Engineers*, 108, 1034, 1417 .
- [5] **Y akao (ed)**, Quality Function Deployment, Productivity Press, Cambridge, MA,1990
- [6] **Fukushi Kenichi, Narita Yoshihiro**, Study on Function and Failure Analysis of Snow Melting Machines, *Transactions of the Japan Society of Mechanical Engineers Series C*, 2002, 68, 675, pp3447-3455
- [7] **Takeo Kato, Tetsuo. Ikeyama, Yoshiyuki Matsuoka**, Classification System for Robust Design Methods, *Proceedings of workshop on Product & System Design*, 42-47,2005
- [8] **Hartung, J., Mergl, C., Bubb, H.**, Reliability of Pressure Measurement on Car Seats, *SAE Tech Pap Ser (Soc Automot Eng)*, SAE-2004-01-2167, 2004
- [9] **Park, S.J., Kim, S., W., Kim, C.J.**, A Study on the Assessment of Driver's Fatigue, *SAE Tech Pap Ser (Soc Automot Eng)*, SAE-2002-01-0784, 2002
- [10] **Demontis, S., Giacoletto, M.**, Prediction of Car Seat Comfort from Human-Seat Interface Pressure Distribution, *SAE Tech Pap Ser (Soc Automot Eng)*, SAE-2002-01-0781, 2002

Contact: Yuji Nomura
Keio University
Graduate School of Science and Technology
3 - 14 - 1 Hiyoshi, Kohoku - ku, Yokohama, 223 - 8522
Japan
Tel : + 81 - 45 - 563 - 1151
e-mail : yuji_nomura@2006.jukuin.keio.ac.jp
URL : <http://www.matsuoka.mech.keio.ac.jp/>